



Almonte River Viaduct

1 Viaduct over River Almonte in Spain almost finished

High performance self-compacting concrete arch bridge for HSR-line Madrid – Lisbon

The high speed railway line Madrid-Lisbon crosses over River Almonte with a great 384 meters arch made of high performance self-compacting concrete (C80). The construction of the viaduct, with a total length of 996 m, started in April 2011, and its loading tests were undertaken late 2016.

Guillermo Capellán,
Javier Martínez,
Emilio Merino
Arenas & Asociados,
Ingeniería de Diseño
Pascual García-Arias
Idom

During the initial stages of the project, different structural alternatives for the Almonte River Viaduct were analyzed in a detailed typological study, considering simultaneously its final behavior as well as its erection procedure. Some of these alternatives included cable-stayed, frame type and variable depth truss deck options. The multi-criteria analysis highlighted the concrete arch solution as the most economical, the best in terms of durability and maintenance conditions, and the one that guaranteed a better structural behavior against dynamic trainloads and wind.

The exceptional span of the arch and the specific considerations of high speed rail (HSR) bridges (dynamic effects by passing trains significantly larger than road traffic, significant horizontal loads and fatigue) led to the design of an innovative structural scheme in HSR arch viaducts, using two separate hexagonal sections in the arch springing that join into an octagonal one in the central stretch of the arch (fig. 2).

In order to verify the structural behavior for static and dynamic loads (deflections, accelerations), specific verifications and advanced nonlinear structural models, for every stage of the construction, were carried out. The stability of the arch was verified for all the critical loading combinations, making a geometric-and-material nonlinear analysis, and using step-by-step iterative techniques.

The complex erection procedure required unique and specific auxiliary members during construction. The arch was erected by the cantilever construction method with the aid of temporary

- 2 Conceptual sketch of the designed bridge
- 3 Arch (a) and deck (b), typical cross section
- 4 Cantilever construction of the arch

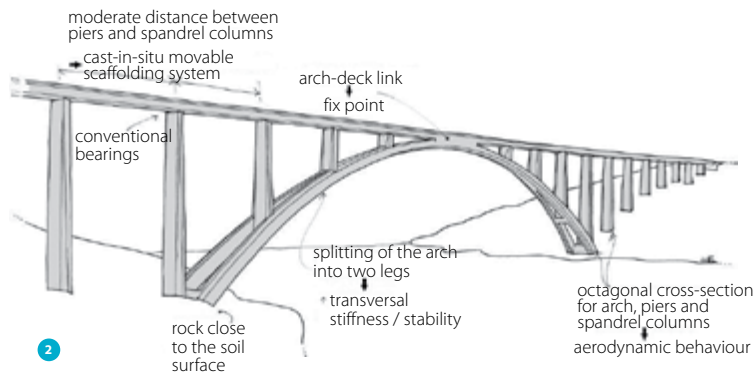

cable-stays from two temporary steel towers, using form travelers specially designed for this bridge; while the deck was constructed using an overhead movable scaffolding system (commonly used method in Spain for HSR concrete box-girder viaducts).

A detailed analysis of all construction phases was performed together by designers (DJV Arenas&Asociados-IDOM) and contractor's technical services (CJV FCC-Conduril) during the construction-stage, and a complete monitoring program was developed to control every step of the building process.

Construction procedure

The construction procedure was developed such that the impact and hinder on the Reservoir of Alcántara is minimized. The main arch crosses over it at a height of almost 60 m, with two access viaducts at both ends completing this scheme. These access viaducts, with moderate typical spans of 45 m, have the same deck geometry over the arch (fig. 3b), in order to use the same overslung movable scaffolding system.

The arch is erected with a cable-stayed cantilever method (photo 4). The total length of the arch is divided into 33 cast in-situ segments on each half, with an approximate length of 6.70 m, plus the key central segment. A cantilever formwork

traveler that fits to all geometries of the arch allows its concreting segment to segment.

In order to ensure that stresses are lower than allowable and the optimal geometry is maintained, the segments are supported by stayed cables during the construction.

There are 26 pairs of stay cables on each side with their corresponding back stays. Cables 1 to 8 (shown in yellow on fig. 5) are anchored to the piers rising on both riverbanks.

The anchorages for cables 9 to 26 (blue on fig. 5) are set on the temporary steel pylons built over piers P6 and P15. Cable forces are adjusted during the construction whilst some cables at intermediate construction stages are being released for avoiding excessive stresses.

After the arch closure is reached, cranes and temporary towers are dismantled to continue with the spandrel columns erection. Subsequently, the last 42 m deck spans over the arch are concreted with the same standard movable scaffolding system (fig. 6 and photo 1).

Other special construction features also deserve to be mentioned:

- Arch's foundations:
 - The arch abutments are two reinforced concrete blocks of 7400 and 6300 m³ that spread the compression loads to the bed rock. The rock around the blocks is heavily injected with 255 tons of cement in order to fill all cracks and discontinuities.
- Retaining foundations:
 - The global equilibrium of the 192 m half-arch cantilevered structure is achieved with multiple anchors placed at the retaining foundations adjacent to the riverbank piers. These anchors have a length of between 22 and 26 m, with a prestressing load of 2000 kN.

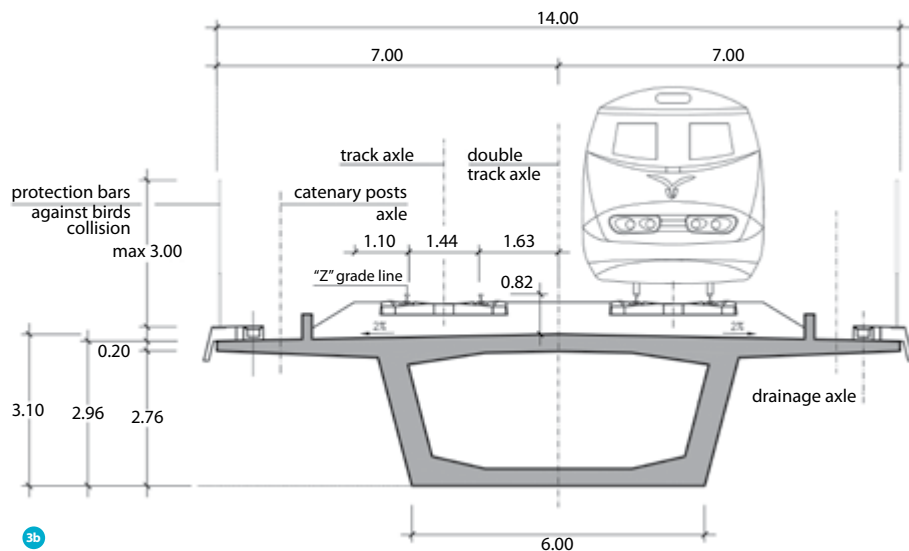
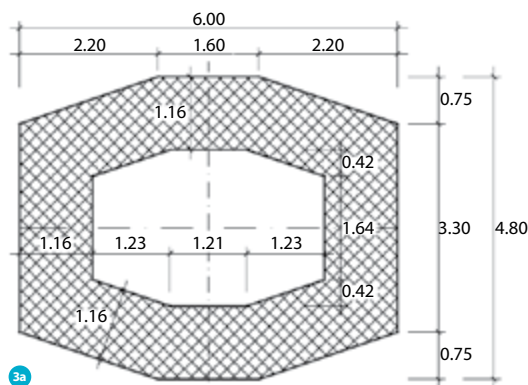

- 5 Numbered scheme of the arch segments and temporary stay cables
- 6 Last construction stages of the deck
- 7,8 Cantilever formwork traveler

- *Cantilever formwork traveler:*

The concreting of the arch is made segment by segment with a cantilever formwork traveler (photo 7 and 8) that fits to all geometries of arch: from segment 1 to 15 the arch is two legged and from 16 to 33 is only one piece varying in width and depth.

- *Temporary towers:*

The articulated temporary steel towers were placed on the arch's edge piers. A rotation operation was undertaken in order to raise both towers from their horizontal position over the deck (fig. 9 and photo 10). This procedure was composed of four different erection stages:

1. hinge placement;
2. tower assembly and auxiliary members' installation;
3. rotating operation;
4. disassembly of auxiliary members. This system allowed execution time savings.

- *Temporary stay cables:*

The stay cables are individually-protected multi-strand cables, identical to permanent stay cables (steel type Y 1860 S7; 150 mm² section). The number of strands varies from Ø 15 to 53 (15.2 mm each). The strands are not galvanized as



4

enough corrosion protection is achieved by a semi-bonded individual HDPE sheath extruded into the strand after the interstices were filled with wax.

Usually both ends of the stay cable were articulated in vertical direction in order to facilitate their installation.

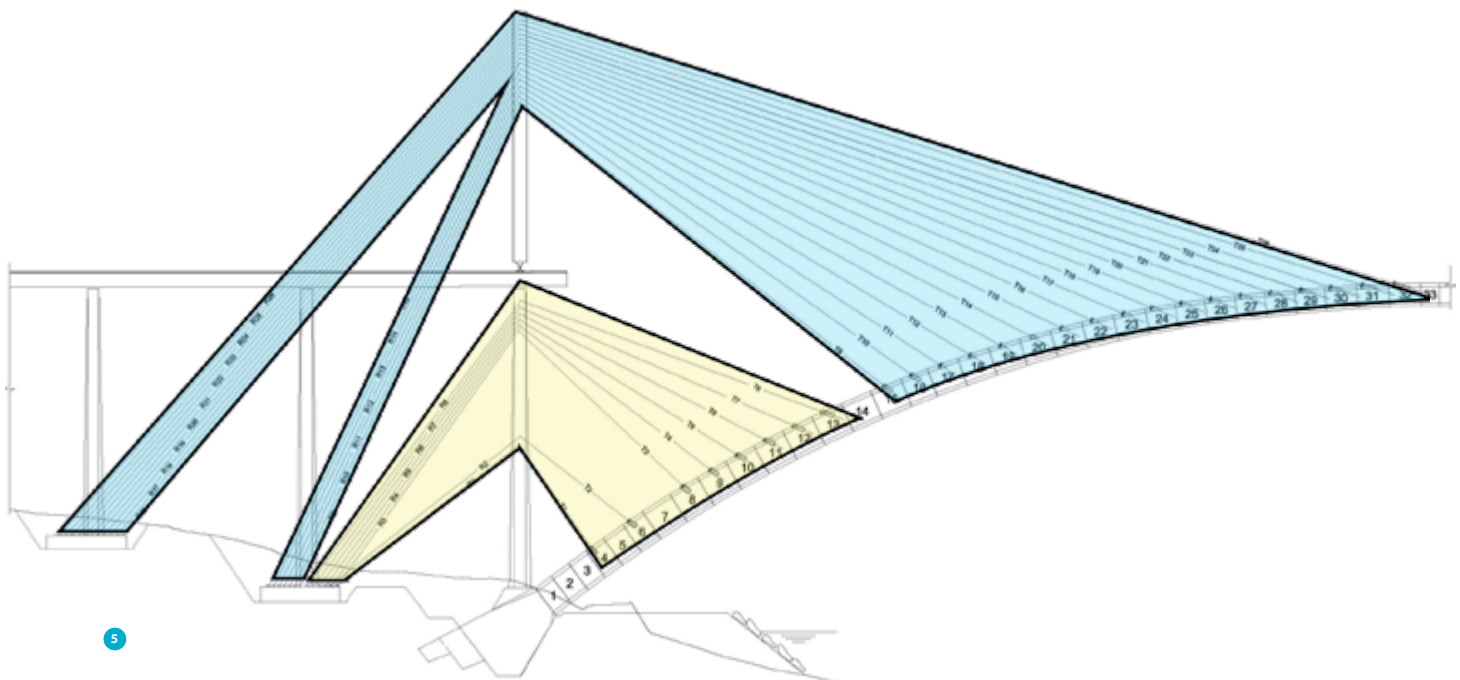

5

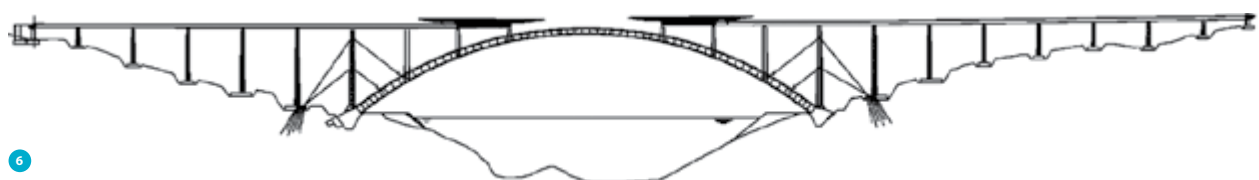

6



7

Monitoring of the bridge

The erection of a bridge with such particular construction features requires permanent structural monitoring, starting during its execution and continuing throughout its entire service life. For a perfectly controlled and functioning structure, it is essential to know the behaviour of the different sections, which will enable monitoring of its service life conditions. For this reason a full scale measurement program was implemented. Staff was organized at three levels that influence each other and interact continuously:

1. A surveyor company records, maintains and presents the data showing the behavior of the structure.
2. A primary analysis makes an immediate coherence evaluation with theoretical predictions providing them to the bridge designer, and simultaneously assesses the perfection of records.
3. At this level, the total station survey is compiled with an automatic data-acquisition measurement system.
4. This primary analysis is developed by an independent engineer, different to the staff of levels one to three.
5. A secondary analysis evaluates in depth the correlation with theoretical predictions and makes corrections to model calculations in order to improve the accuracy of forecast and appraise the origin and consequences of divergences. The installed system initially included 93 points of recording in each side of the bridge, listed in table 1.

Table 1 Recorded parameters of Almonte Bridge (only one semi-arch)

N°	parameter	points of recording
1	wind direction	1
2	wind speed	1
3	external air temperature	1
4	internal arch air temperature	1
5	stay cable temperature	6
6	concrete arch temperature	12
7	concrete pylon temperature	4
8	steel tower temperature	4
9	foundation clinometer	4
10	concrete pylon clinometer	1
11	steel tower clinometer	2
12	arch clinometer	2
13	concrete pylon clinometer	1
14	arch rebar strain gauge	12
15	steel tower strain gauge	4
16	stay cable strain gauge	40



8

- 9, 10 Elevation of temporary steel tower
- 11 Geometry control points of cantilever formwork traveler

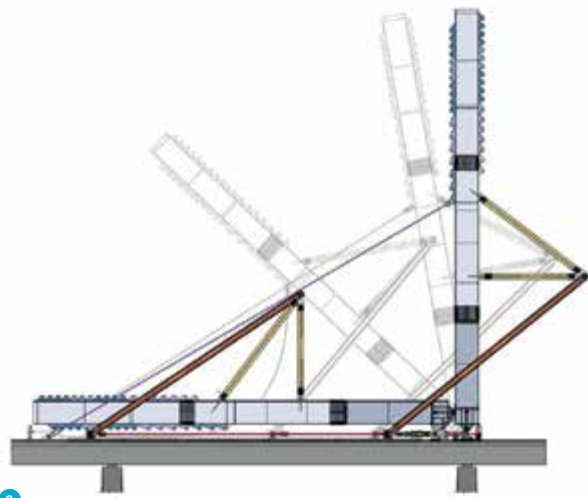

9

The system was further improved with the addition of 5 accelerometers on the arch to analyze the dynamic behavior with the following purposes:

1. Continuous measurement and recording of the vertical and horizontal accelerations;
2. Empirical evaluation of vibration modes of arch in construction stages;
3. Evolution of vibration modes of the bridge in time.

Data was automatically transformed to the engineering units on site, and presented via website to the three supervision levels.

Geometry control of arch construction

For an optimal structural performance, the arch's geometry should match the best as possible with the geometric thrust line axis for all load combinations. It is concluded that the best practice and construction philosophy, is to achieve structure's overall geometric control, by performing field survey work and erection operations (forces of stays and cantilever formwork placement) to a meticulous degree of accuracy.

In this sense, it was necessary to carry out continuous and comprehensive studies of the structure under each erection stage, determining the corresponding stress and geometric data, preparing a step-by-step erection procedure plan and incorporating any checked measurement that was desirable. Under certain construction load conditions (wind, temperature, gravity loads), it was necessary to check the structural integrity of arch, stays, piers and foundations.

The placement of cantilever formwork travelers was controlled by four reflectors fixed at the end of the formwork (fig. 11). It was then possible to determine the position of the end of the



10

cantilever arch at any stage and compare it with theoretical calculations. This way the structure could be controlled along its whole length and at any time during erection.

Since movements of the different stages grew and the system became more flexible, and therefore more susceptible to other effects (e.g. temperature on the stay cables), alarms were defined in sections of segments. The allowed tolerances were: segments 1 to 15 (± 50 mm), segments 16 to 13 (± 100 mm) and segments 24 to 32 (± 180 mm).

It should be noted that the final construction errors were never greater than 88 mm.

Conclusions

The use of vanguard current technology and construction techniques, has allowed the execution of this engineering challenge. Among them all, it must be highlighted the high performance concrete allowing to adopt a more slender arch section, the four legged arch configuration, the nonlinear and evolving calculation software and techniques, the aeroelastic wind tunnel modelling, and the semi-probabilistic normative treatments, as key elements for the design and structural validation of the Viaduct over River Almonte. ☒

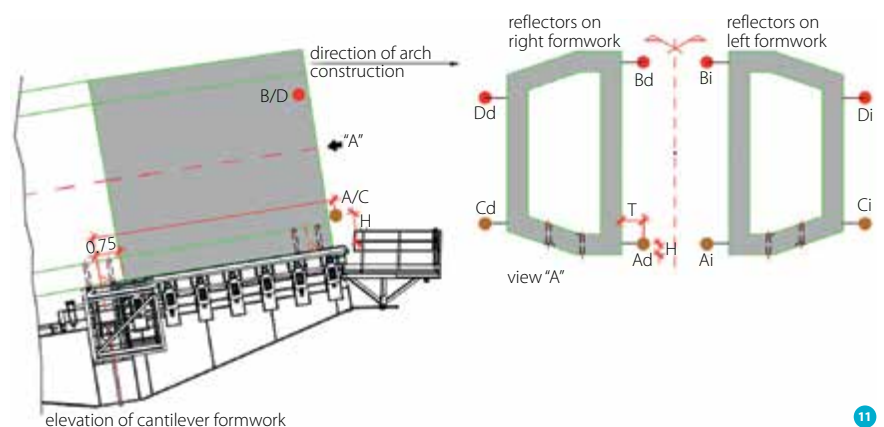

elevation of cantilever formwork

11